

## USonic™ Series

### Ultrasonic Level Transmitter



**Affordable, 2-Wire Level Transmitter with the performance and features of premium, line-powered systems.**

#### 2-inch Nozzle Mounting

Compact transducer design allows mounting in any 2-inch nozzle. It also allows for a recessed nozzle mounting enabling level to be read to the very top of the vessel.

#### SMARTGain™

(SMARTGain™) Eliminates interfering signals from agitators and other internal vessel obstructions without the need to empty the vessel and without operator intervention. Easily ignores pipes and obstructions that are in the sonic beam path.

#### Two-Wire Loop Powered, HART®

30 ft. Range (9.1 meter)  
Intrinsic Safety and Explosion Proof designs and Approvals (pending)

#### Easy set-up

Via PC software or HART Communicator  
Menu driven configuration via integral display

#### SMARTGain™

Automatically ignores most internal obstructions  
No user adjustments required

#### Full Tank Measurement

Transducer can be recessed in a 2-inch ID, or larger, nozzle to allow level measurements to the very top of the vessel.

#### Bench Configuration

Eliminates the need to move process material levels for calibration.

#### Level or Open Channel Flow measurements

Integrated software supports measurement in Level, Distance, Volume or Flow

#### User Friendly

Set the measurement range directly in inches, feet, millimeters, centimeters, or meters via the integral display with environmentally sealed keypad. The display is menu driven and can easily be configured without detailed procedures: no cryptic codes, no problems.

#### Level and Open Channel Flow measurements

The USonic makes measurements on level, distance, volume or open channel flow easy to configure. Preset flume and weir characterizations are included in the USonic for over 80 different flumes and weirs. Custom characterizations can be user defined for flumes/weirs that are uncommon. Each USonic contains 2 totalizers (one is user resettable).

#### Ideal for hazardous area installations

Units designed for either Intrinsically Safe or Explosion Proof installations in Class 1 Div. 1, Zone 0 environments.



# Continuous Level Measurement

## Usonic™ Series Ultrasonic Level Transmitter

### Specifications

**Input Power**

19 to 30 VDC  
19 VDC required @ 4 mA  
minimum

**Output signal**

2-wire, 4-20mA, HART (isolated)

**Maximum Loop Resistance**

600 ohms at 24VDC

**Output Mode**

Level, Distance, Flow, Volume

**Display Indications**

Level, Distance, Flow rate,  
Totalization, Temperature,  
Signal Strength, Milliamp  
User selectable, multiple  
selections can be scrolled  
automatically

**Supported Flow elements:**

Parshall  
Rectangular Weirs (with and  
without end contractions)  
Trapezoidal (Weir and Flume)  
V-Notch  
Leopold-Lagco  
Palmer-Bowlus  
“H” Flumes

**Range**

1 to 30 ft. (0.3 to 9.1m)

**Near Zone**

12 inches (305 mm)

**Minimum Span**

3 inches (76 mm)

**Maximum Span**

30 ft. (9.1 m)

**Response Time**

300 millisecond

**Display**

2-line, 7-digit LCD  
Character height: 0.25” top line,  
0.36” bottom line  
UV Rated - Sunshield not  
required

**Accuracy**

+/- 0.15% or 0.2 inch (5 mm) of  
sensor range, which ever is  
greater

**Repeatability**

<0.12 inch (3 mm)

**Resolution**

<0.12 inch (3 mm)

**Ambient Temperature Limits**

-40°F to 158°F (-40°C to 70°C)

**Temperature Compensation**

Built-in, Automatic and readable  
from display

**Fail-Safe**

3.7 and 22 mA error signals  
– user selectable for Lost Echo  
and Near Zone violations

**Configuration**

Local Display with Keypad (XP  
version non-indicating)  
PC Software (I.S. and XP  
versions)  
HART Communicator (I.S. and  
XP versions)

**Signal Damping**

User programmable from 0 – 99  
seconds

**Auto Profiling™**

Standard feature on every  
system

**Sensor**

6.5” CPVC,  
I.S. rated -40°F to +158°F at  
50 psig. (-40°C to +70°C at 3.4  
bar)  
XP rated -12°F to +158°F at  
50 psig. (-25°C to +70°C at 3.4  
bar)

**Sensing element connection**

2-inch NPT/BSP fitting, CPVC  
Flange mounting (via threaded  
flanges)

**Frequency**

50KHz

**Beam Angle**

Conical, 10° (total) @ 3db down

**Electrical Enclosures**

PBT-RF (Valox UV Stabilized) to  
NEMA 4X (IP-66)  
Explosion proof, powder coated  
aluminum to NEMA 4X (IP-66) /  
IP68 (3m / 72h)

**Approvals**

Class I, Div. 1 & Div. 2, Zone 0  
& Zone 1 hazardous locations.  
FM, FMc, CE, ATEX, IEC EX

# Continuous Level Measurement

## Usonic™ Series Ultrasonic Level Transmitter

### Model Numbering

#### Usonic™

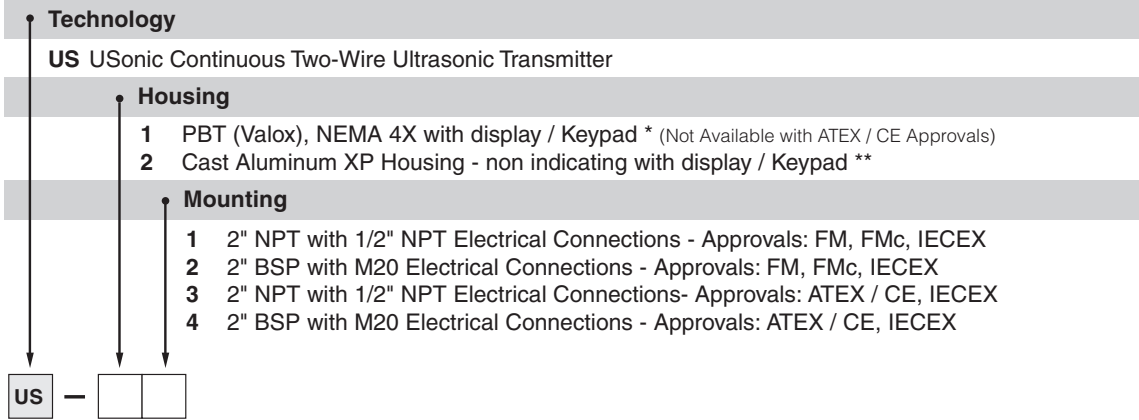

\* Intrinsic Safety Approvals

\*\* Intrinsic Safety Approvals & FM / FMc Approved Explosion Proof

\* Model Number subject to change without notice

### Ignore difficult internal obstructions with patented SMARTGain™

SMARTGain™ is a standard feature with every system and prevents unwanted reflections from internal obstructions and agitator blades. By automatically controlling the transmitter gain (sensitivity to returned echoes), without user intervention, it is possible to ignore obstructions that are mounted within the ultrasonic beam path. SMARTGain™ also provides measurement advantages in horizontal cylinders and spheres by reducing the effects of multiple reflection signal paths.

### Ignore Obstructions in the Beam Path

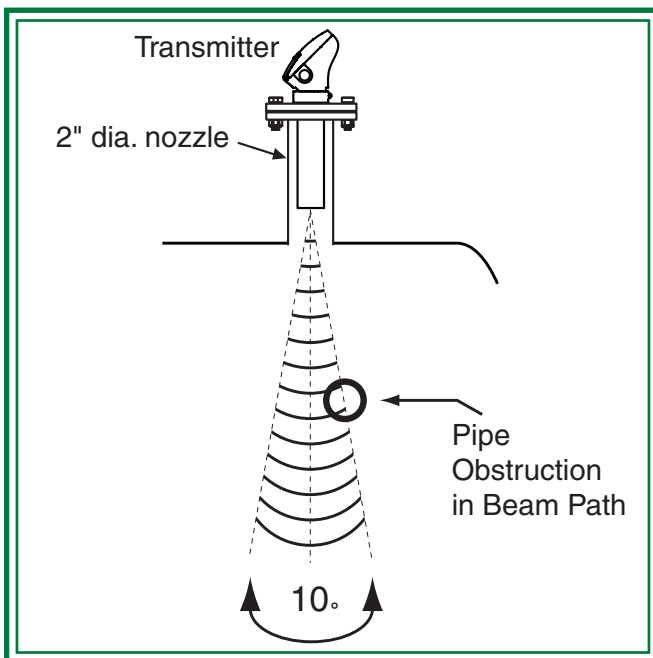

- The edge of a 2-inch (50 mm) pipe can be as close as ½ inch (12 mm) from the centerline of the transducer, and ignored.
- The edge of a 1-inch (25 mm) pipe can be 1-inch (25 mm) from the centerline of the transducer, and ignored.

# Continuous Level Measurement

## Usonic™ Series Ultrasonic Level Transmitter

### Quick Start-up:

1. Choose Level, Distance, Volume, or Flow as an input type.
2. Choose Configuration Units (Feet, Inches, Meters, Centimeters, Millimeters).
3. Enter Tank Height.
4. Enter LRV and URV (4 & 20 mA points).

**That's all that is needed to start measuring accurate Level!**

### Easy user-defined configuration as simple or complex as needed.

In addition to a quick and easy start-up, in-depth configuration allows the conversion of Level to Volume through internal strapping tables or open channel flow tables and totalizer settings. The Usonic has (2) 7-digit totalizers on-board for use in flow measurement inputs; one is user resettable. Systems settings allow user-defined system gain, repetition rates, time delay, error signals, display options, HART® Communication, diagnostics and more.

### System Dimensional Drawings:

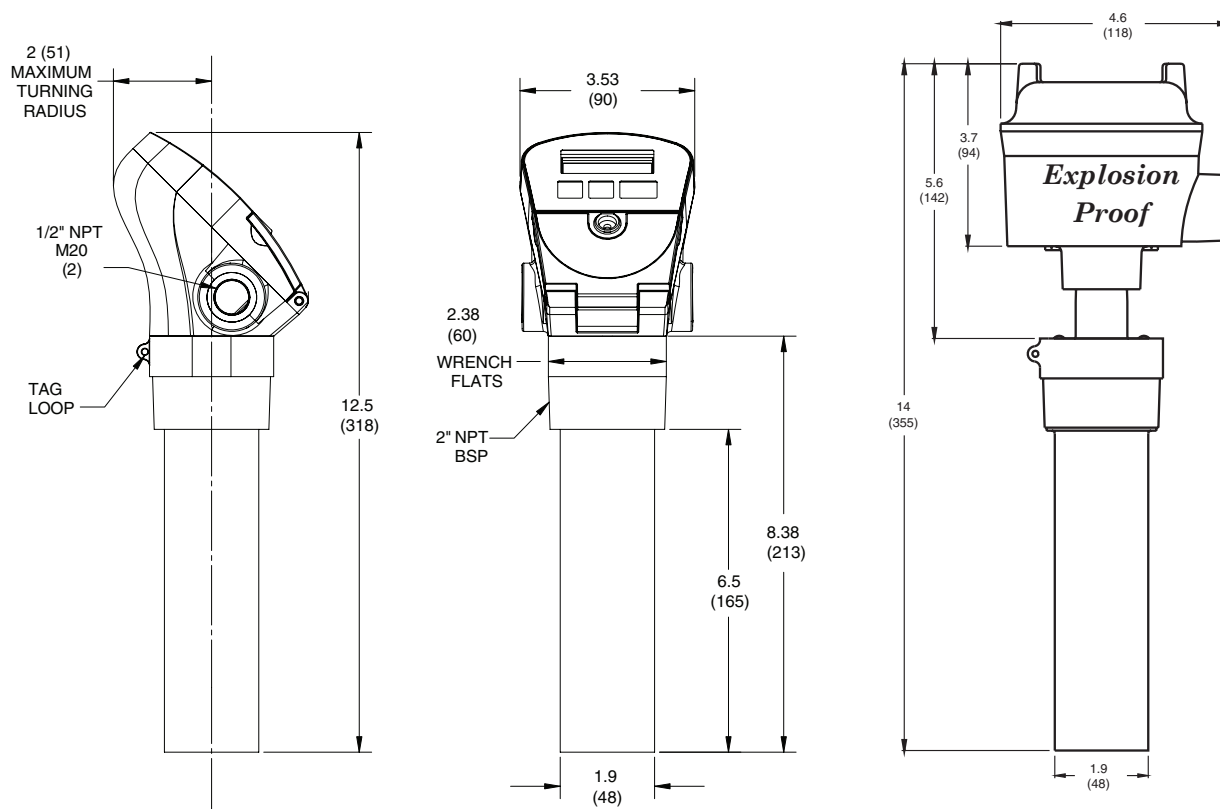

**AMETEK® DREXELBROOK®**

205 Keith Valley Road, Horsham, PA 19044 U.S.A.

Tel: 215-674-1234 Fax: 215 674-2731

Email: [drexelbrook.info@ametek.com](mailto:drexelbrook.info@ametek.com)

Web: [www.drexelbrook.com](http://www.drexelbrook.com)